

Products Description

Lightning arrester, alternate named lightning protection devices, used for protecting the building when raining and lightning. The lightning rod installed on the building and transfer the electric to earthing metal to protect the building. Our SLE lightning rod comply with GB standard. Customized lightning rod available.

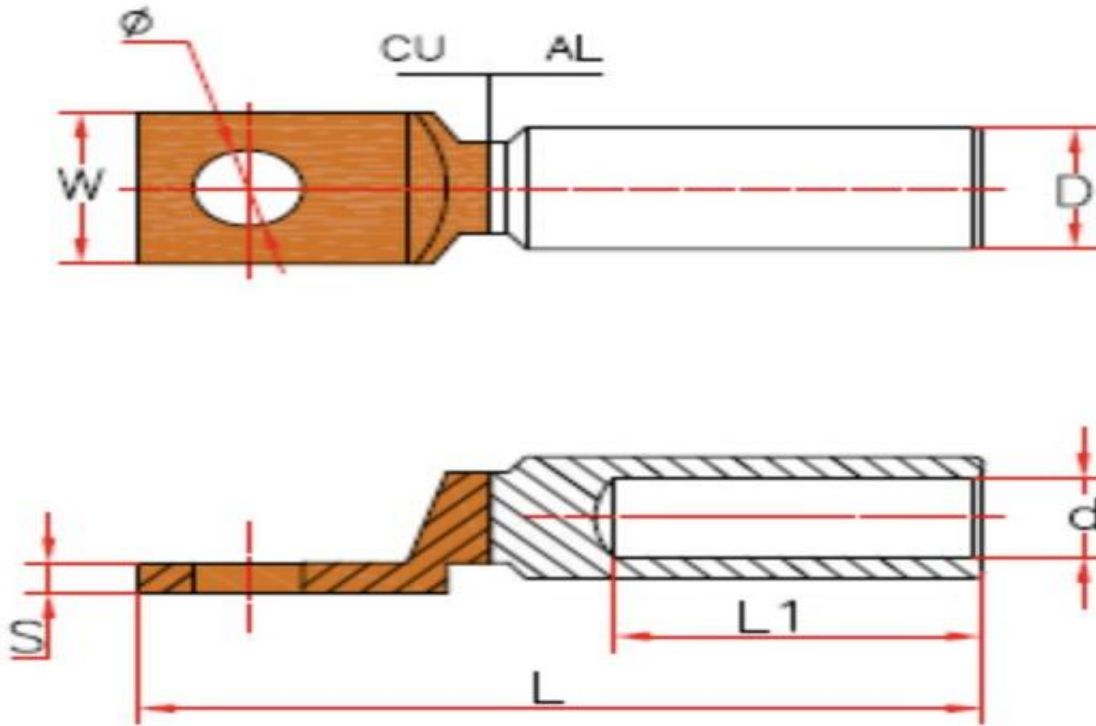

Product Parameter

Material	Copper or Brass or Copper Clad Steel or Stainless Steel
Size	according to customer's requirement
Life	More than 50 Years
Characters	Easy installation, long life

Product Size

Description	Size	Material
Lightning rod	Dia7mmxL250mm	copper clad steel or stainless steel
Three point needle	Dia7mmxL9mm	
Ball	Dia18mm	
Holder	Dia85mmxH60mm	
Base	100mmx100mmx2mm	
Total Height	370mm	